



Shenzhen CTA Testing Technology Co., Ltd.

Room 106, Building 1, Yibaolai Industrial Park, Qiaotou Community, Fuhai Street, Bao'an District, Shenzhen, China

TEST REPORT
ETSI EN 300 422-1 V2.2.1 (2021-11)

Report Reference No.: CTA24082301101

Tested by (position+printed name+signature): File administrators Jinghua Xiao

Review by (position+printed name+signature): Project Engineer Xudong Zhang

Approved by (position+printed name+signature): RF Manager Eric Wang

Date of issue: Aug. 30, 2024

Testing Laboratory Name: Shenzhen CTA Testing Technology Co., Ltd.

Address: Room 106, Building 1, Yibaolai Industrial Park, Qiaotou Community, Fuhai Street, Bao'an District, Shenzhen, China

Applicant's name: Η εταιρεία Κ. ΜΙΧΟΣ και ΣΙΑ Ο.Ε.

Address: Chalandriou Str. 5, Ag. Paraskevi Athens 15343, Greece

Test specification:

Standard: ETSI EN 300 422-1 V2.2.1 (2021-11)

Shenzhen CTA Testing Technology Co., Ltd. All rights reserved.

This publication may be reproduced in whole or in part for non-commercial purposes as long as the Shenzhen CTA Testing Technology Co., Ltd. is acknowledged as copyright owner and source of the material.

Test item description: UHF wireless microphone

Trade Mark: GILBORD

Manufacturer: Η εταιρεία Κ. ΜΙΧΟΣ και ΣΙΑ Ο.Ε.

Model/Type reference: WRL848+WRLM-18

List Model: WRL838TDV+WRLM-10, WRL858+WRLM-11, WRL718+WRLM-12, WRL728+WRLM-13, WRL738+WRLM-14, WRL868instr+WRLM-15, WRL750+WRLM-16, REC850+LA-12 TROLLEY MIC, WRL838+WRLM-17

Modulation: FM

Operation Frequency: 660.3-690.0MHz

Hardware version: V1.0

Software version: V1.0

Ratings: TX: DC 3.0V From battery

RX: DC 12.0V From external circuit

Result: PASS



Shenzhen CTA Testing Technology Co., Ltd.

Room 106, Building 1, Yibaolai Industrial Park, Qiaotou Community, Fuhai Street, Bao'an District, Shenzhen, China

Tel:+86-755 2322 5875 E-mail:cta@cta-test.cn Web:http://www.cta-test.cn

### TEST REPORT

Equipment under Test : UHF wireless microphone

Model /Type : WRL848+WRLM-18

Listed Models : WRL838TDV+WRLM-10, WRL858+WRLM-11,  
WRL718+WRLM-12, WRL728+WRLM-13, WRL738+WRLM-14,  
WRL868instr+WRLM-15, WRL750+WRLM-16,  
REC850+LA-12 TROLLEY MIC, WRL838+WRLM-17

**Applicant** : **Η εταιρεία Κ. ΜΙΧΟΣ και ΣΙΑ Ο.Ε.**

Address : Chalandriou Str. 5, Ag. Paraskevi Athens 15343, Greece

**Manufacturer** : **Η εταιρεία Κ. ΜΙΧΟΣ και ΣΙΑ Ο.Ε.**

Address : Chalandriou Str. 5, Ag. Paraskevi Athens 15343, Greece

<b>Test Result</b>	<b>PASS</b>
--------------------	-------------

The test report merely corresponds to the test sample.  
It is not permitted to copy extracts of these test result without the written permission of the test laboratory.

## Contents

<b>1.</b>	<b><u>TEST SUMMARY .....</u></b>	<b>4</b>
1.1.	Test Standards	4
1.2.	Test Description	4
1.3.	Test Laboratory	4
1.4.	Statement of the measurement uncertainty	4
<b>2.</b>	<b><u>SUMMARY .....</u></b>	<b>6</b>
2.1.	General Remarks	6
2.2.	Product Description	6
2.3.	Equipment Under Test	6
2.4.	Description of Test Modes and Test Frequency	6
2.5.	Equipments Used during the Test	8
<b>3.</b>	<b><u>TEST CONDITIONS AND RESULTS .....</u></b>	<b>9</b>
3.1.	Frequency stability	9
3.2.	Rated output power	10
3.3.	Necessary bandwidth	11
3.4.	Transmitter spurious emissions	13
3.5.	Transmitter intermodulation distortion	17
3.6.	Receiver spurious emissions	18
3.7.	Receiver sensitivity	22
3.8.	Receiver adjacent channel selectivity	23
3.9.	Receiver blocking	24
<b>4.</b>	<b><u>TEST SETUP PHOTOS OF THE EUT .....</u></b>	<b>26</b>
<b>5.</b>	<b><u>EXTERNAL AND INTERNAL PHOTOS OF THE EUT .....</u></b>	<b>27</b>

# 1. TEST SUMMARY

## 1.1. Test Standards

The tests were performed according to following standards:

[ETSI EN 300 422-1 V2.2.1 \(2021-11\)](#) WIRELESS MICROPHONE; Audio PMSE up to 3 GHz; Part 1: Audio PMSE Equipment up to 3 GHz; Harmonised Standard for access to radio spectrum

## 1.2. Test Description

Item	Reference	Result
Frequency stability	ETSI EN 300 422-1 V2.2.1 (2021-11) Sub-clause 4.2.2	PASS
RF Output Power	ETSI EN 300 422-1 V2.2.1 (2021-11) Sub-clause 4.2.1	PASS
Necessary bandwidth transmitter	ETSI EN 300 422-1 V2.2.1 (2021-11) Sub-clause 4.2.3	PASS
Spurious emissions transmitter	ETSI EN 300 422-1 V2.2.1 (2021-11) Sub-clause 4.2.4	PASS
Transmitter intermodulation distortion	ETSI EN 300 422-1 V2.2.1 (2021-11) Sub-clause 4.2.5	PASS
Spurious emissions receiver	ETSI EN 300 422-1 V2.2.1 (2021-11) Sub-clause 4.3.5	PASS
Receiver sensitivity	ETSI EN 300 422-1 V2.2.1 (2021-11) Sub-clause 4.3.2	PASS
Receiver adjacent channel selectivity	ETSI EN 300 422-1 V2.2.1 (2021-11) Sub-clause 4.3.3	PASS
Receiver Blocking	ETSI EN 300 422-1 V2.2.1 (2021-11) Sub-clause 4.3.4	PASS

## 1.3. Test Laboratory

The test facility is recognized, certified, or accredited by the following organizations:

**FCC-Registration No.: 517856 Designation Number: CN1318**

Shenzhen CTA Testing Technology Co., Ltd. has been listed on the US Federal Communications Commission list of test facilities recognized to perform electromagnetic emissions measurements.

**A2LA-Lab Cert. No.: 6534.01**

Shenzhen CTA Testing Technology Co., Ltd. has been listed by American Association for Laboratory Accreditation to perform electromagnetic emission measurement.

The 3m-Semi anechoic test site fulfils CISPR 16-1-4 according to ANSI C63.10 and CISPR 16-1-4:2010

## 1.4. Statement of the measurement uncertainty

The data and results referenced in this document are true and accurate. The reader is cautioned that there may be errors within the calibration limits of the equipment and facilities. The measurement uncertainty was calculated for all measurements listed in this test report acc. to TR-100028-01 "Electromagnetic compatibility and Radio spectrum Matters (ERM);Uncertainties in the measurement of mobile radio equipment characteristics; Part 1" and TR-100028-02 "Electromagnetic compatibility and Radio spectrum Matters (ERM);Uncertainties in the measurement of mobile radio equipment characteristics; Part 2 " and is documented in the Shenzhen CTA Testing Technology Co., Ltd. quality system acc. to DIN EN ISO/IEC 17025. Furthermore, component and process variability of devices similar to that tested may result in additional deviation. The manufacturer has the sole responsibility of continued compliance of the device. Hereafter the best measurement capability for Shenzhen CTA Testing Technology Co., Ltd.

**Shenzhen CTA Testing Technology Co., Ltd.**

Room 106, Building 1, Yibaolai Industrial Park, Qiaotou Community, Fuhai Street, Bao'an District, Shenzhen, China  
Tel:+86-755 2322 5875 E-mail:cta@cta-test.cn Web:http://www.cta-test.cn

Test	Range	Measurement Uncertainty	Notes
Radiated Emission	9KHz~30MHz	3.02 dB	(1)
Radiated Emission	30~1000MHz	4.06 dB	(1)
Radiated Emission	1~18GHz	5.14 dB	(1)
Radiated Emission	18-40GHz	5.38 dB	(1)
Conducted Disturbance	0.15~30MHz	2.14 dB	(1)
Output Peak power	30MHz~18GHz	0.55 dB	(1)
Power spectral density	/	0.57 dB	(1)
Spectrum bandwidth	/	1.1%	(1)
Radiated spurious emission (30MHz-1GHz)	30~1000MHz	4.10 dB	(1)
Radiated spurious emission (1GHz-18GHz)	1~18GHz	4.32 dB	(1)
Radiated spurious emission (18GHz-40GHz)	18-40GHz	5.54 dB	(1)

- (1) This uncertainty represents an expanded uncertainty expressed at approximately the 95% confidence level using a coverage factor of k=2.

## 2. SUMMARY

### 2.1. General Remarks

Date of receipt of test sample	:	Aug. 24, 2024
Testing commenced on	:	Aug. 24, 2024
Testing concluded on	:	Aug. 30, 2024

### 2.2. Product Description

Product Name:	UHF wireless microphone
Model/Type reference:	WRL848+WRLM-18
Power supply:	TX: DC 3.0V From battery RX: DC 12.0V From external circuit
Adapter information:	Model: TY-801A Input: AC 100-240V 50/60Hz 0.25A Output: DC 12V 1A
<b>Wireless microphone</b>	
Operation frequency:	660.3-690.0MHz
Modulation Type:	FM
Antenna	TX: Internal antenna, 0.8dBi (Max) RX: External antenna, 2.0dBi (Max)

### 2.3. Equipment Under Test

#### Power supply system utilised

Power supply voltage	:	<input type="radio"/> 230V / 50 Hz	<input type="radio"/> 120V / 60Hz
		<input type="radio"/> 12 V DC	<input type="radio"/> 24 V DC
		<input checked="" type="radio"/> Other (specified in blank below)	

TX: DC 3.0V From battery

RX: DC 12.0V From external circuit

### 2.4. Description of Test Modes and Test Frequency

The EUT has been tested under typical operating condition. The Applicant provides communication tools software to control the EUT for staying in continuous transmitting and receiving mode for testing. There is 100 channels provided to the EUT. Channel Low, Mid, High was selected to test

Channel	Frequency(MHz)	Channel	Frequency(MHz)
1	660.3	51	675.3
2	660.6	52	675.6
3	660.9	53	675.9
4	661.2	54	676.2
5	661.5	55	676.5
6	661.8	56	676.8
7	662.1	57	677.1
8	662.4	58	677.4
9	662.7	59	677.7
10	663.0	60	678.0

Shenzhen CTA Testing Technology Co., Ltd.

Room 106, Building 1, Yibaolai Industrial Park, Qiaotou Community, Fuhai Street, Bao'an District, Shenzhen, China  
Tel:+86-755 2322 5875 E-mail:cta@cta-test.cn Web:http://www.cta-test.cn



11	663.3	61	678.3
12	663.6	62	678.6
13	663.9	63	678.9
14	664.2	64	679.2
15	664.5	65	679.5
16	664.8	66	679.8
17	665.1	67	680.1
18	665.4	68	680.4
19	665.7	69	680.7
20	666.0	70	681.0
21	666.3	71	681.3
22	666.6	72	681.6
23	666.9	73	681.9
24	667.2	74	682.2
25	667.5	75	682.5
26	667.8	76	682.8
27	668.1	77	683.1
28	668.4	78	683.4
29	668.7	79	683.7
30	669.0	80	684.0
31	669.3	81	684.3
32	669.6	82	684.6
33	669.9	83	684.9
34	670.2	84	685.2
35	670.5	85	685.5
36	670.8	86	685.8
37	671.1	87	686.1
38	671.4	88	686.4
39	671.7	89	686.7
40	672.0	90	687.0
41	672.3	91	687.3
42	672.6	92	687.6
43	672.9	93	687.9
44	673.2	94	688.2
45	673.5	95	688.5
46	673.8	96	688.8
47	674.1	97	689.1
48	674.4	98	689.4
49	674.7	99	689.7
50	675.0	100	690.0

**Testing Frequency List:**

Channel	Frequency(MHz)
Low	660.30
Mid	675.00
High	690.00

## 2.5. Equipments Used during the Test

Test Equipment	Manufacturer	Model No.	Equipment No.	Calibration Date	Calibration Due Date
LISN	R&S	ENV216	CTA-308	2024/08/03	2025/08/02
LISN	R&S	ENV216	CTA-314	2024/08/03	2025/08/02
EMI Test Receiver	R&S	ESPI	CTA-307	2024/08/03	2025/08/02
EMI Test Receiver	R&S	ESCI	CTA-306	2024/08/03	2025/08/02
Spectrum Analyzer	Agilent	N9020A	CTA-301	2024/08/03	2025/08/02
Spectrum Analyzer	R&S	FSU	CTA-337	2024/08/03	2025/08/02
Vector Signal generator	Agilent	N5182A	CTA-305	2024/08/03	2025/08/02
Analog Signal Generator	R&S	SML03	CTA-304	2024/08/03	2025/08/02
Universal Radio Communication	CMW500	R&S	CTA-302	2024/08/03	2025/08/02
Temperature and humidity meter	Chigo	ZG-7020	CTA-326	2024/08/03	2025/08/02
Ultra-Broadband Antenna	Schwarzbeck	VULB9163	CTA-310	2023/10/17	2024/10/16
Horn Antenna	Schwarzbeck	BBHA 9120D	CTA-309	2023/10/13	2024/10/12
Loop Antenna	Zhinan	ZN30900C	CTA-311	2023/10/17	2024/10/16
Horn Antenna	Beijing Hangwei Dayang	OBH100400	CTA-336	2023/10/17	2024/10/16
Amplifier	Schwarzbeck	BBV 9745	CTA-312	2024/08/03	2025/08/02
Amplifier	Taiwan chengyi	EMC051845B	CTA-313	2024/08/03	2025/08/02
Directional coupler	NARDA	4226-10	CTA-303	2024/08/03	2025/08/02
High-Pass Filter	XingBo	XBLBQ-GTA18	CTA-402	2024/08/03	2025/08/02
High-Pass Filter	XingBo	XBLBQ-GTA27	CTA-403	2024/08/03	2025/08/02
Automated filter bank	Tonscend	JS0806-F	CTA-404	2024/08/03	2025/08/02
Power Sensor	Agilent	U2021XA	CTA-405	2024/08/03	2025/08/02
Amplifier	Schwarzbeck	BBV9719	CTA-406	2024/08/03	2025/08/02

Test Equipment	Manufacturer	Model No.	Version number	Calibration Date	Calibration Due Date
EMI Test Software	Tonscend	TS@JS32-RE	5.0.0.2	N/A	N/A
EMI Test Software	Tonscend	TS@JS32-CE	5.0.0.1	N/A	N/A
RF Test Software	Tonscend	TS@JS1120-3	3.1.65	N/A	N/A
RF Test Software	Tonscend	TS@JS1120	3.1.46	N/A	N/A



### 3. TEST CONDITIONS AND RESULTS

#### 3.1. Frequency stability

**LIMIT**

The frequency error shall not exceed 20 parts per million for frequencies below 1 GHz, 15 parts per million between 1 GHz and 2 GHz, and 10 ppm above 2 GHz.

**TEST CONFIGURATION**

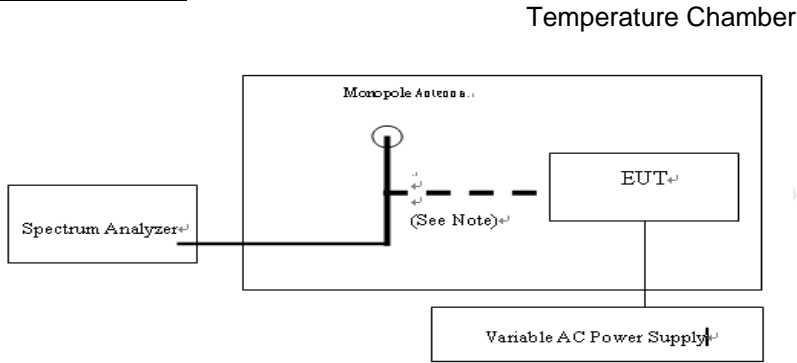

**TEST PROCEDURE**

1. Please refer to ETSI EN 300 422-1 clause 5.1 for the test conditions.
2. Please refer to ETSI EN 300 422-1 clause 5.4.2 for the measurement method.

**TEST RESULTS**

Test Frequency (MHz)	Temperature (°C)	AC Power	Frequency error(KHz)	Frequency error(ppm)	Limit (ppm)	Verdict
660.30	25°C	3.00 V	2.5	3.79	20	PASS
	+45°C	3.30 V	1.6	2.42		
	-10°C	2.70 V	2.9	4.39		
	+45°C	3.30 V	2.2	3.33		
	-10°C	2.70 V	2.9	4.39		
675.00	25°C	3.00 V	3.5	5.19	20	PASS
	+45°C	3.30 V	2.7	4.00		
	-10°C	2.70 V	4.2	6.22		
	+45°C	3.30 V	2.6	3.85		
	-10°C	2.70 V	4.1	6.07		
690.00	25°C	3.00 V	3.3	4.78	20	PASS
	+45°C	3.30 V	3.1	4.49		
	-10°C	2.70 V	4.3	6.23		
	+45°C	3.30 V	3.7	5.36		
	-10°C	2.70 V	2.2	3.19		

### 3.2. Rated output power

**LIMIT**

The measured value shall be within +20 % and -50 % of the manufacturer's declared rated output power.

**TEST CONFIGURATION**

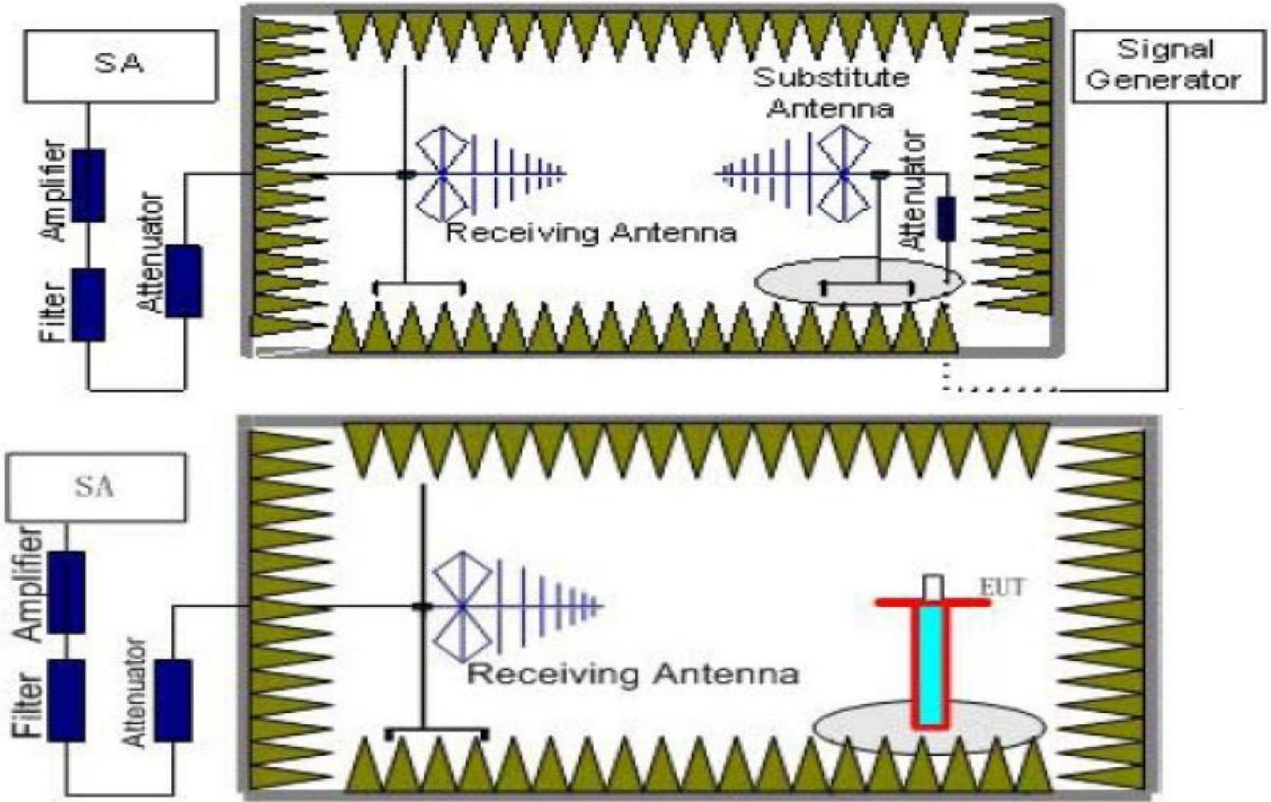

**TEST PROCEDURE**

1. Please refer to ETSI EN 300 422-1 clause 5.1 for the test conditions.
2. Please refer to ETSI EN 300 422-1 clause 5.4.1 for the measurement method.

**TEST RESULTS**

Channel (MHz)	Antenna Polarity	ERP (dBm)	Rated output power (dBm)	Tolerance (%)	Limit	Result
660.30	V	8.45	10.00	-15.50%	-50%~20%	Pass
	H	9.54	10.00	-4.60%		
675.00	V	8.99	10.00	-10.10%	-50%~20%	Pass
	H	9.61	10.00	-3.90%		
690.00	V	8.81	10.00	-11.90%	-50%~20%	Pass
	H	9.38	10.00	-6.20%		

### 3.3. Necessary bandwidth

**LIMIT**

**ETSI EN 300422-1 Sub-clause 4.2.3**

The transmitter output spectrum shall be within the mask defined in figure 3 where B is the declared channel bandwidth

**TEST CONFIGURATION**

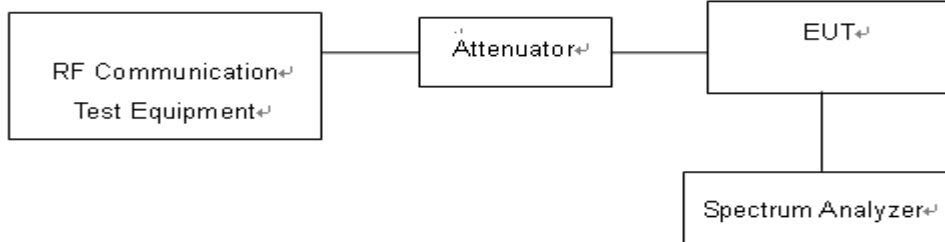

**TEST PROCEDURE**

1. With the Low Frequency (LF) audio signal generator set to 500 Hz, the audio input level to the EUT shall be Adjusted to 8 dB below the limiting threshold (-8dB limit) as declared by the manufacturer.
2. The corresponding audio output level from the demodulator shall be measured and recorded.
3. The input impedance of the noise meter shall be sufficiently high to avoid more than 0.1 dB changes in input level when the meter is switched between input and output.
4. The audio input level shall be increased by 20 dB, i.e. to 12 dB (lim), and the corresponding change in output level shall be measured.
5. It shall be checked that the audio output level has increased by  $\leq 10$  dB.
6. If the step 5 is not met, the initial audio input level shall be increased from -8 dB (lim) in 1 dB steps until the above condition is fulfilled, and the input level recorded in the test report. This level replaces the value derived from the manufacturer's declaration and is defined as -8dB (lim).
7. Measure the input level at the transmitter required to give +12 dB (lim) and record the EUT output level test plots by the spectrum analyzer.

**TEST RESULTS**

**Note:**

	<b>Bandwidth(B)</b>	<b>B/2</b>	<b>0.35B</b>
Manufacturer declare	100 KHz	50KHz	30KHz

**Pass**

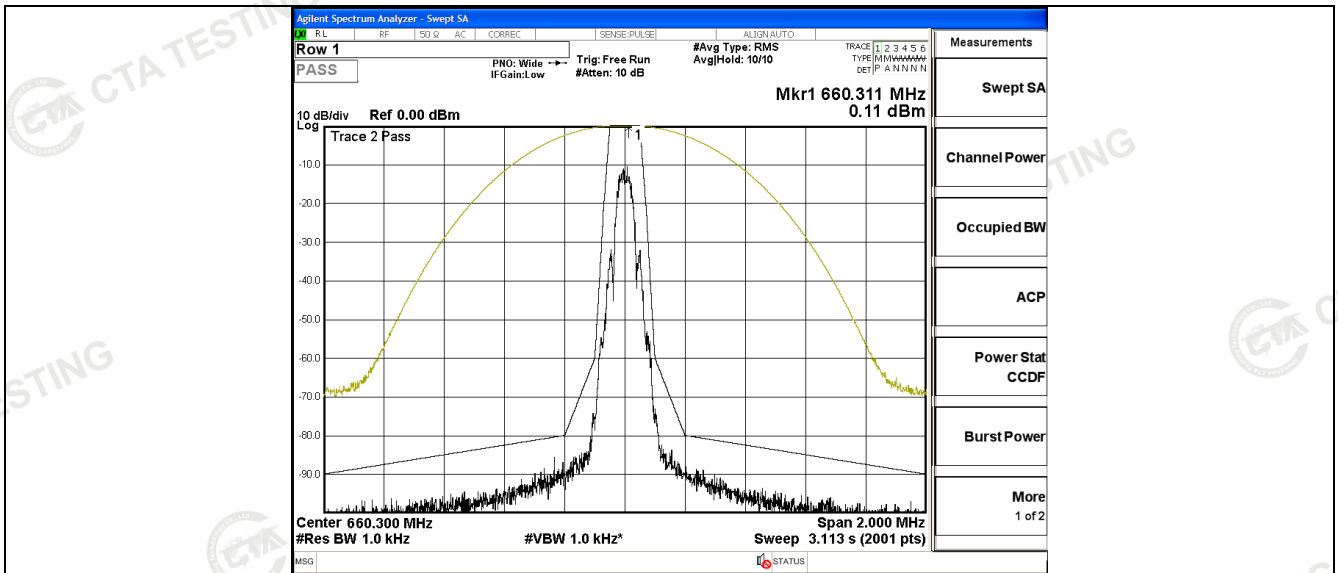

660.30 MHz

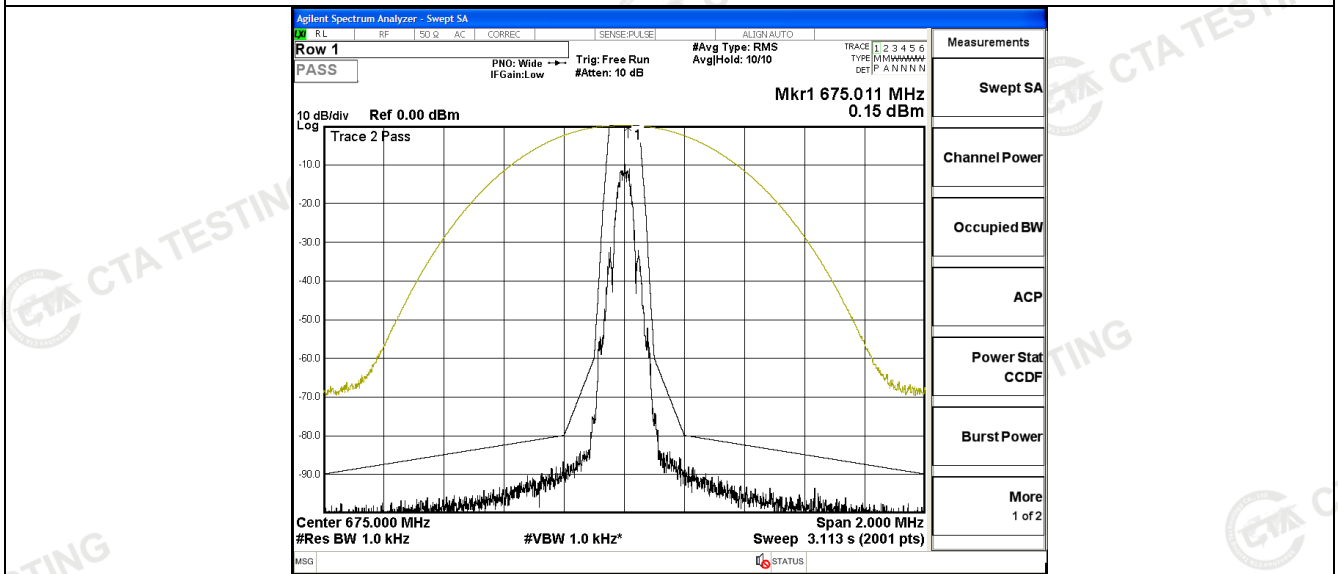

675.00 MHz

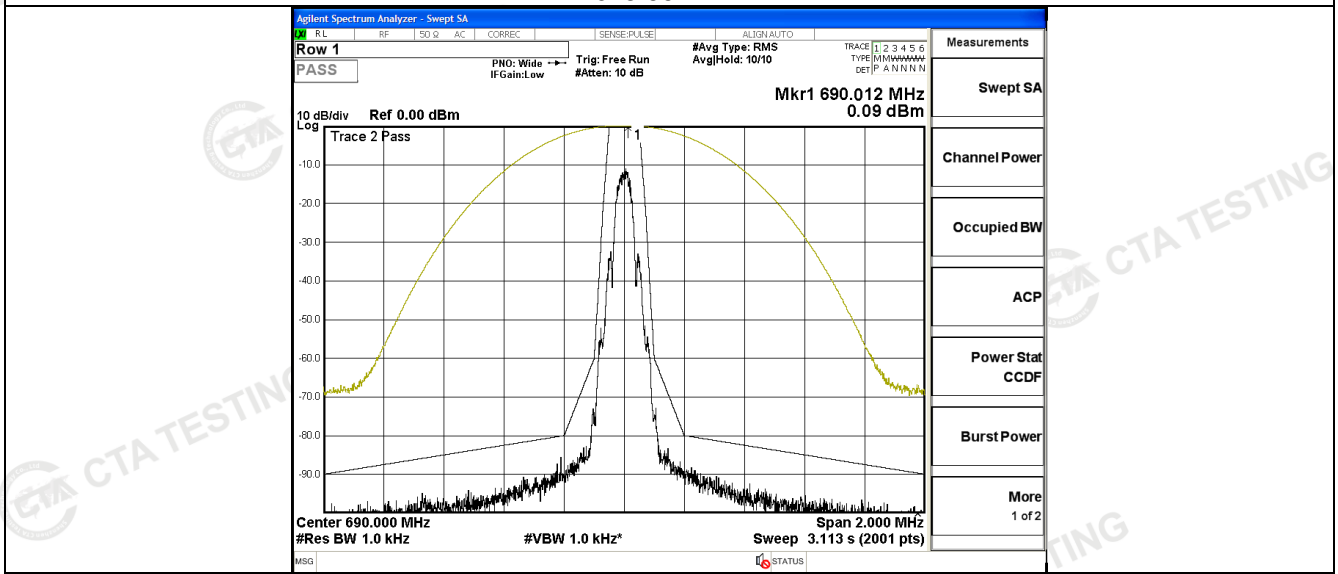

690.00 MHz



### 3.4. Transmitter spurious emissions

#### LIMIT

Spurious emissions are emissions outside the frequency range(s) of the equipment. The power of the spurious emissions shall not exceed the limits of table as below:

State	Frequency		
	47 MHz to 74 MHz 87,5 MHz to 137 MHz 174 MHz to 230 MHz 470 MHz to 862 MHz	Other Frequencies below 1 000 MHz	Frequencies above 1 000 MHz
Operation	4 nW	250 nW	1 μW
Standby	2 nW	2 nW	20 nW

#### TEST CONFIGURATION

Effective Radiated Power measurement (30 MHz to 12.75 GHz)

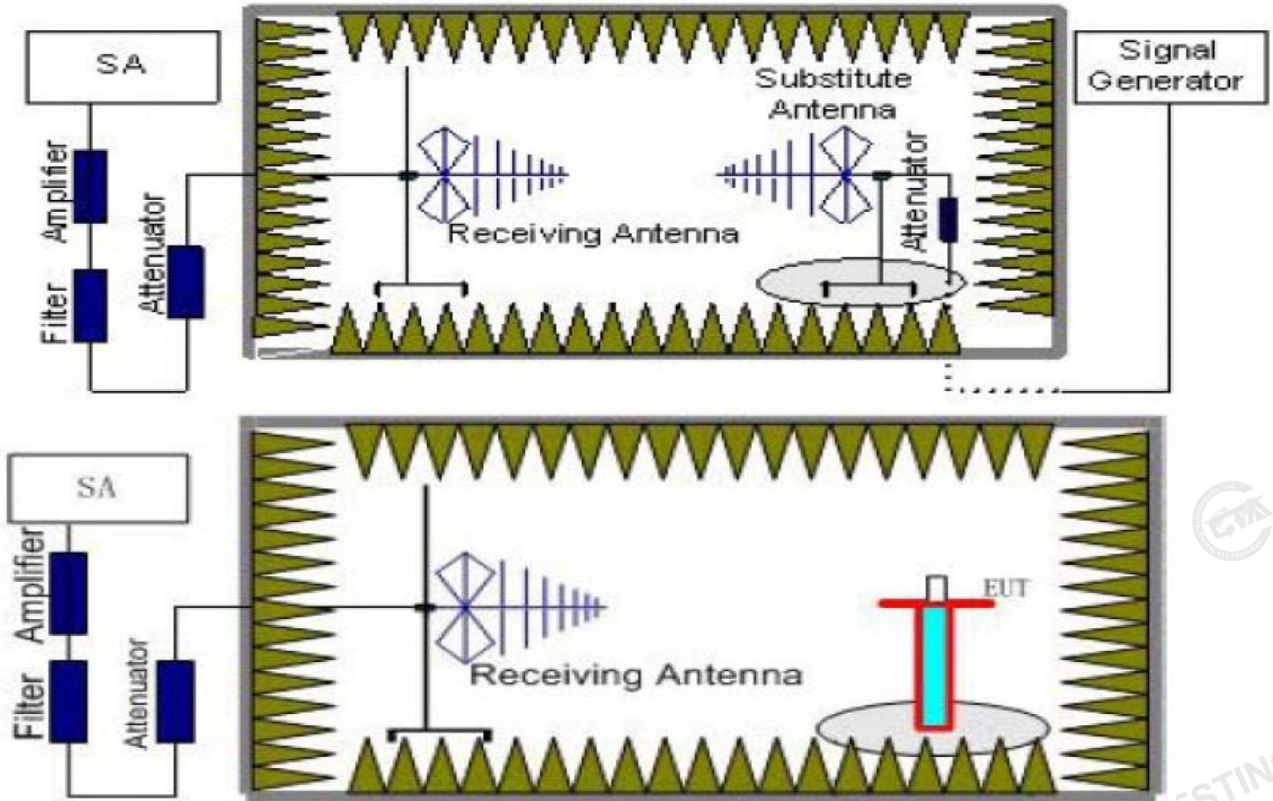

#### TEST PROCEDURE

1. Please refer to ETSI EN 300 422-1 clause 5.1 for the test conditions.
2. Please refer to ETSI EN 300 422-1 clause 5.4.4 for the measurement method.

**TEST RESULTS**

The test frequency range from 25MHz to 10GHz and recorded worst at below:

**Note 1: While performing the testing, the notch filter is used for avoiding test instrument overload.**

**Note 2: This test was performed with EUT in X, Y, Z position and the worst case was found when EUT in X position.**

**Tx in operation mode lowest carrier = 660.30 MHz**

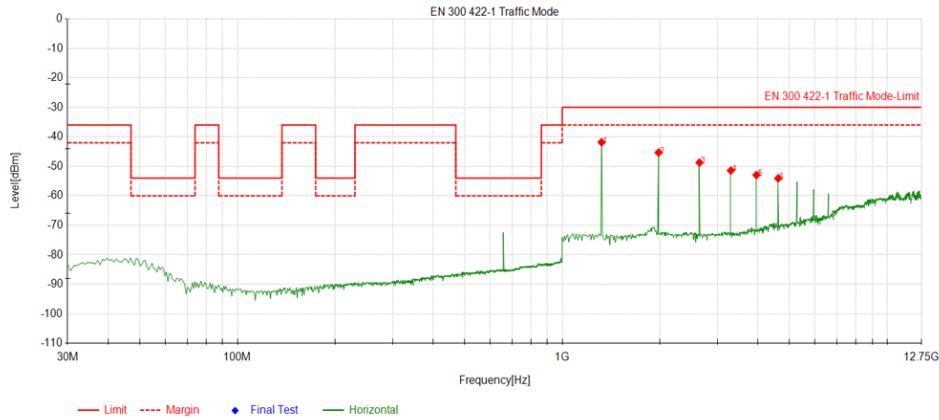

Suspected Data List								
NO.	Freq. [MHz]	Reading [dBm]	Level [dBm]	Limit [dBm]	Margin [dB]	Factor [dB]	Path [dB]	Polarity
1.	1320.6.	-28.91.	-41.83.	-30.00.	11.83.	-12.92.	-48.63.	Horizontal.
2.	1980.9.	-35.55.	-45.31.	-30.00.	15.31.	-9.76.	-49.03.	Horizontal.
3.	2641.2.	-36.48.	-48.72.	-30.00.	18.72.	-12.24.	-49.20.	Horizontal.
4.	3301.5.	-40.56.	-51.40.	-30.00.	21.40.	-10.84.	-48.60.	Horizontal.
5.	3961.8.	-42.58.	-52.95.	-30.00.	22.95.	-10.37.	-48.23.	Horizontal.
6.	4622.1.	-45.28.	-54.07.	-30.00.	24.07.	-8.79.	-48.00.	Horizontal.

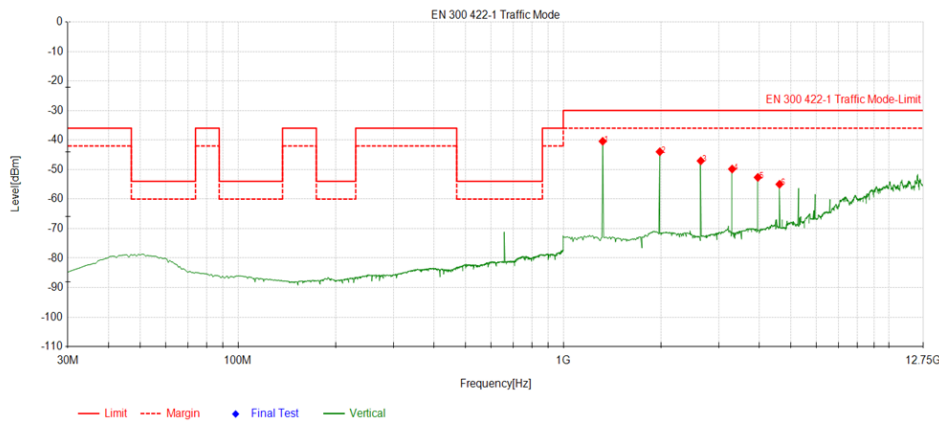

Suspected Data List								
NO.	Freq. [MHz]	Reading [dBm]	Level [dBm]	Limit [dBm]	Margin [dB]	Factor [dB]	Path [dB]	Polarity
1.	1320.6.	-27.61.	-40.41.	-30.00.	10.41.	-12.80.	-48.63.	Vertical.
2.	1980.9.	-32.80.	-43.96.	-30.00.	13.96.	-11.16.	-49.03.	Vertical.
3.	2641.2.	-34.68.	-47.04.	-30.00.	17.04.	-12.36.	-49.20.	Vertical.
4.	3301.5.	-38.71.	-49.82.	-30.00.	19.82.	-11.11.	-48.60.	Vertical.
5.	3961.8.	-42.43.	-52.65.	-30.00.	22.65.	-10.22.	-48.23.	Vertical.
6.	4622.1.	-45.74.	-54.97.	-30.00.	24.97.	-9.23.	-48.00.	Vertical.



**Tx in operation mode lowest carrier = 675.00 MHz**

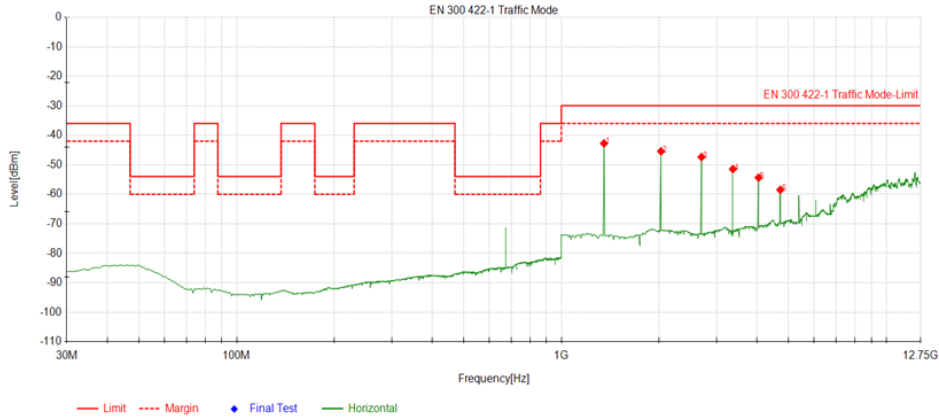

Suspected Data List								
NO.	Freq. [MHz]	Reading [dBm]	Level [dBm]	Limit [dBm]	Margin [dB]	Factor [dB]	Path [dB]	Polarity
1	1350	-30.01	-42.74	-30.00	12.74	-12.73	-48.43	Horizontal
2	2025	-34.25	-45.44	-30.00	15.44	-11.19	-49.04	Horizontal
3	2700	-35.07	-47.37	-30.00	17.37	-12.30	-49.17	Horizontal
4	3375	-40.27	-51.46	-30.00	21.46	-11.19	-48.51	Horizontal
5	4050	-44.43	-54.37	-30.00	24.37	-9.94	-48.16	Horizontal
6	4725	-50.04	-58.50	-30.00	28.50	-8.46	-47.55	Horizontal

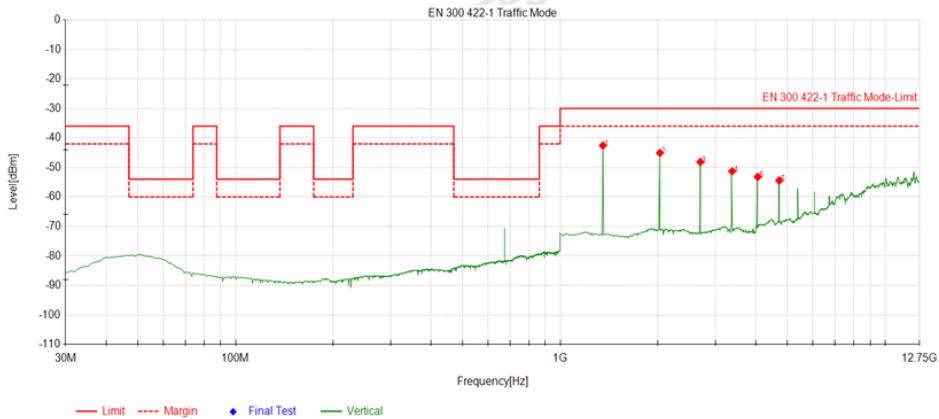

Suspected Data List								
NO.	Freq. [MHz]	Reading [dBm]	Level [dBm]	Limit [dBm]	Margin [dB]	Factor [dB]	Path [dB]	Polarity
1	1350	-29.84	-42.57	-30.00	12.57	-12.73	-48.43	Vertical
2	2025	-33.88	-45.07	-30.00	15.07	-11.19	-49.04	Vertical
3	2700	-35.82	-48.12	-30.00	18.12	-12.30	-49.17	Vertical
4	3375	-40.10	-51.30	-30.00	21.30	-11.20	-48.50	Vertical
5	4050	-43.33	-53.19	-30.00	23.19	-9.86	-48.14	Vertical
6	4725	-45.96	-54.42	-30.00	24.42	-8.46	-47.55	Vertical

**Tx in operation mode lowest carrier = 690.00 MHz**

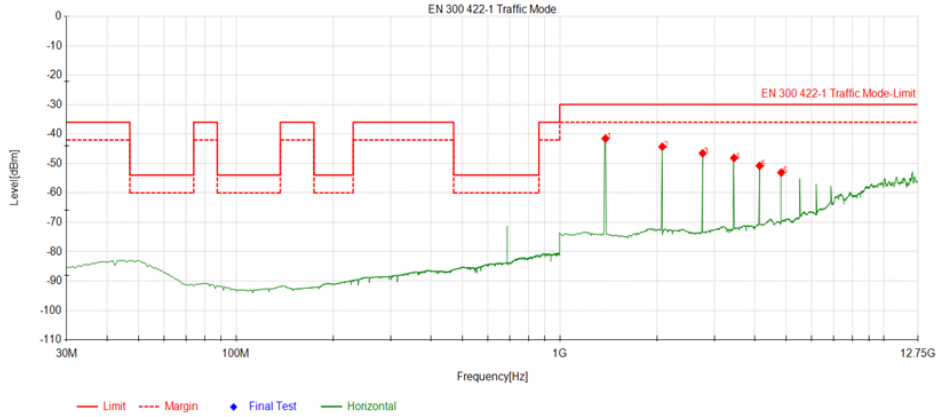

NO.	Freq. [MHz]	Reading [dBm]	Level [dBm]	Limit [dBm]	Margin [dB]	Factor [dB]	Path [dB]	Polarity
1	1380	-28.87	-41.53	-30.00	11.53	-12.66	-48.23	Horizontal
2	2070	-33.26	-44.32	-30.00	14.32	-11.06	-48.67	Horizontal
3	2760	-34.40	-46.55	-30.00	16.55	-12.15	-49.26	Horizontal
4	3450	-37.24	-48.15	-30.00	18.15	-10.91	-48.48	Horizontal
5	4140	-41.36	-50.83	-30.00	20.83	-9.47	-48.02	Horizontal
6	4830	-44.65	-53.09	-30.00	23.09	-8.44	-47.59	Horizontal

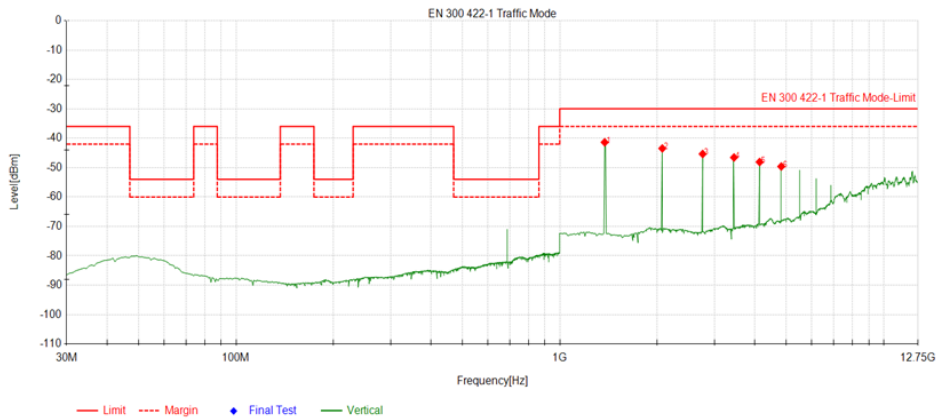

NO.	Freq. [MHz]	Reading [dBm]	Level [dBm]	Limit [dBm]	Margin [dB]	Factor [dB]	Path [dB]	Polarity
1	1380	-28.70	-41.37	-30.00	11.37	-12.67	-48.28	Vertical
2	2070	-32.39	-43.45	-30.00	13.45	-11.06	-48.67	Vertical
3	2760	-33.20	-45.35	-30.00	15.35	-12.15	-49.26	Vertical
4	3450	-35.63	-46.54	-30.00	16.54	-10.91	-48.48	Vertical
5	4140	-38.61	-48.08	-30.00	18.08	-9.47	-48.02	Vertical
6	4830	-41.16	-49.60	-30.00	19.60	-8.44	-47.59	Vertical

**Remark:**

- The test frequency range from 25MHz to 10GHz, RBW/VBW: 100 KHz/300KHz below 1GHz, RBW/VBW: 1000 KHz/3000KHz above 1GHz.  
 “--“Other emission levels were very low against the limit and not reported.
- All modes were tested, only recorded the worst case data in the test report.

### 3.5. Transmitter intermodulation distortion

#### LIMIT

The maximum resulting IMD product shall be at least 40 dB below the output power of the DUT.

#### TEST CONFIGURATION

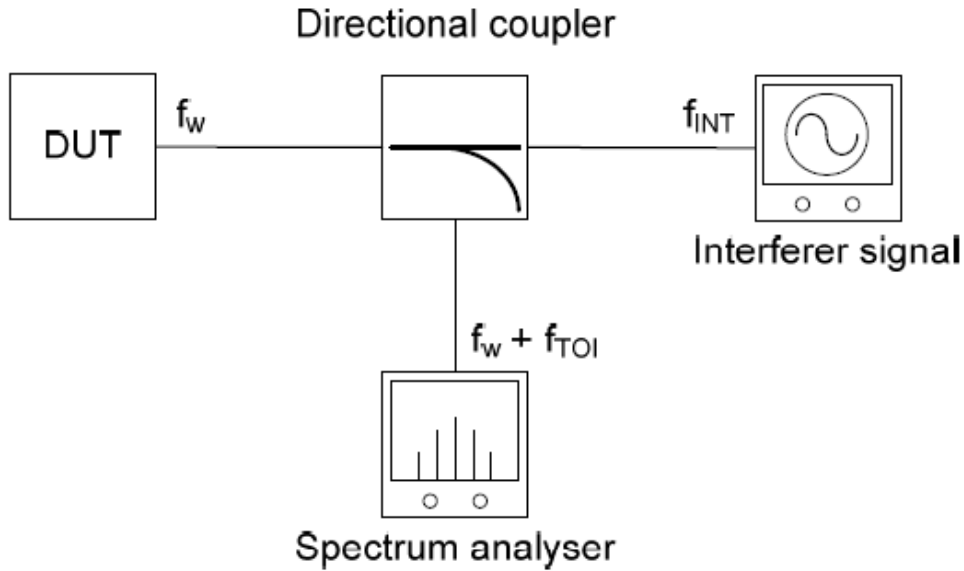

#### TEST PROCEDURE

1. Please refer to ETSI EN 300 422-1 clause 5.1 for the test conditions.
2. Please refer to ETSI EN 300 422-1 clause 5.4.5 for the measurement method.

#### TEST RESULTS

Test frequency (MHz)	Maximum Tx-IMD (dBc)	LIMIT (dBc)	Result
660.30	45	40	Pass
675.00	49	40	Pass
690.00	43	40	Pass

### 3.6. Receiver spurious emissions

**LIMIT**

The power of the spurious emissions shall not exceed the limits of table as below:

Frequency range	Level
30 MHz to 1 GHz	-57 dBm
1 GHz to 12.75GHz	-47 dBm

**TEST CONFIGURATION**

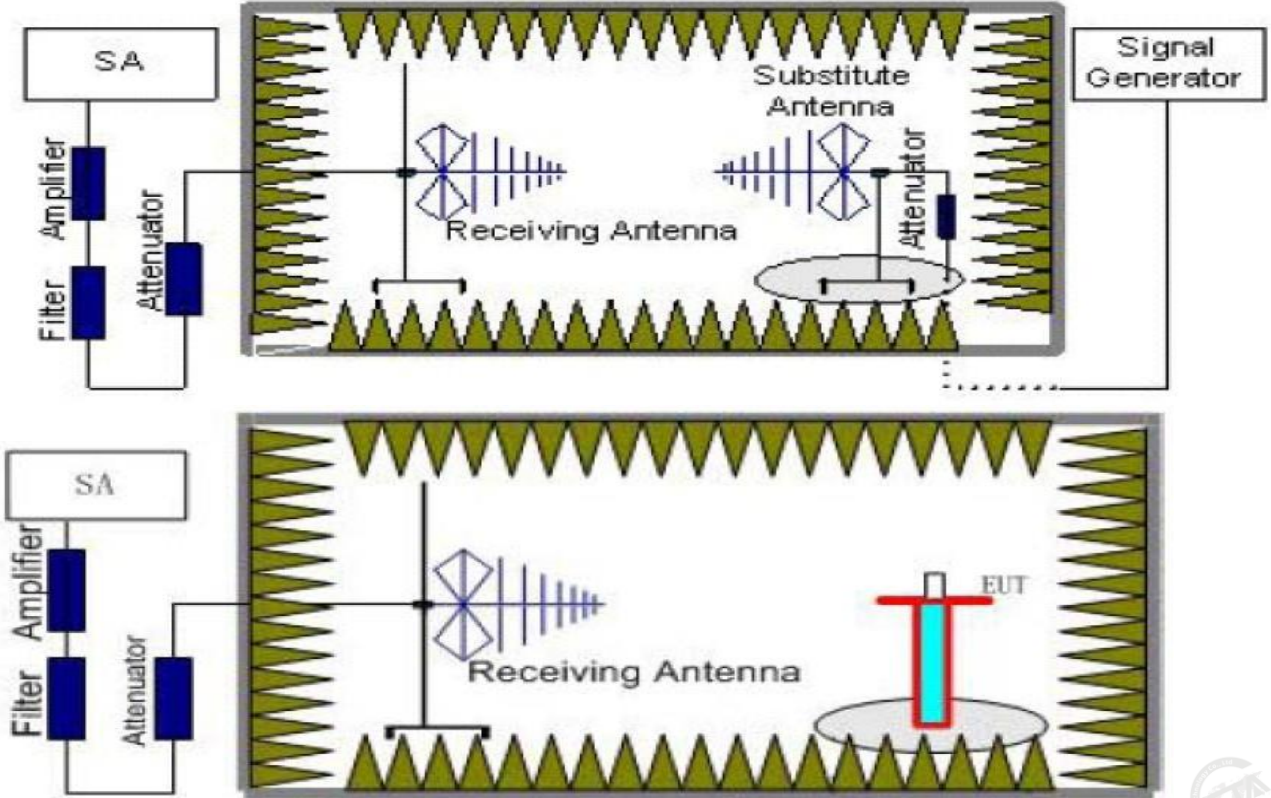

**TEST PROCEDURE**

1. Please refer to ETSI EN 300 422-1 clause 5.1 for the test conditions.
2. Please refer to ETSI EN 300 422-1 clause 5.5.4 for the measurement method.

**TEST RESULTS**

The test frequency range from 25MHz to 10GHz and recorded worst at below:

**Note 1: While performing the testing, the notch filter is used for avoiding test instrument overload.**

**Note 2: This test was performed with EUT in X, Y, Z position and the worst case was found when EUT in X position.**

The test frequency range from 25MHz to 10 GHz and recorded worst at below:

**Rx in operation mode lowest carrier = 660.30 MHz**

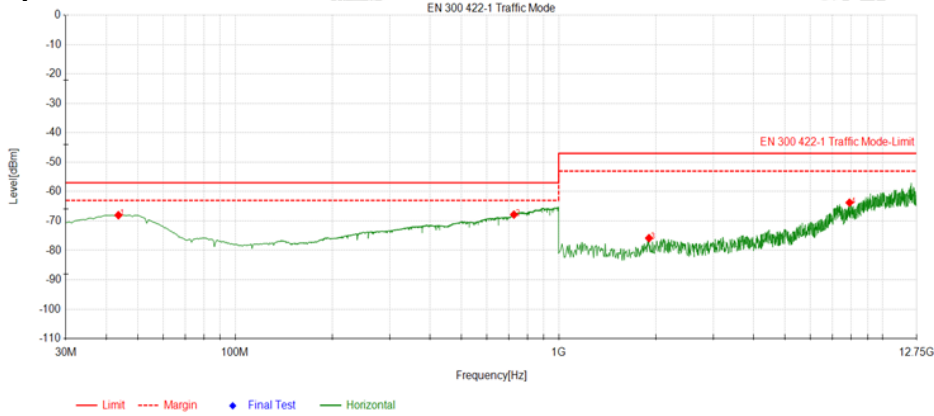

Suspected Data List								
NO.	Freq. [MHz]	Reading [dBm]	Level [dBm]	Limit [dBm]	Margin [dB]	Factor [dB]	Path [dB]	Polarity
1	43.58	-65.02	-68.02	-57.00	11.02	-3.00	-30.59	Horizontal
2	727.1067	-65.12	-67.82	-57.00	10.82	-2.70	-30.46	Horizontal
3	1900.833	-65.07	-75.83	-47.00	28.83	-10.76	-48.22	Horizontal
4	7916.833	-65.21	-63.75	-47.00	16.75	1.46	-43.80	Horizontal

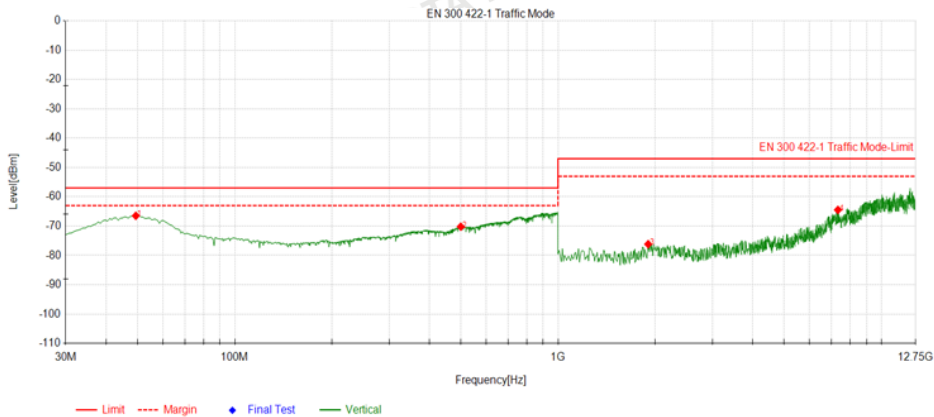

Suspected Data List								
NO.	Freq. [MHz]	Reading [dBm]	Level [dBm]	Limit [dBm]	Margin [dB]	Factor [dB]	Path [dB]	Polarity
1	49.4	-65.03	-66.48	-57.00	9.48	-1.45	-30.44	Vertical
2	500.1267	-65.08	-70.19	-57.00	13.19	-5.11	-30.65	Vertical
3	1900.833	-65.39	-76.15	-47.00	29.15	-10.76	-48.22	Vertical
4	7345	-65.21	-64.47	-47.00	17.47	0.74	-44.45	Vertical



Rx in operation mode lowest carrier = 675.00 MHz

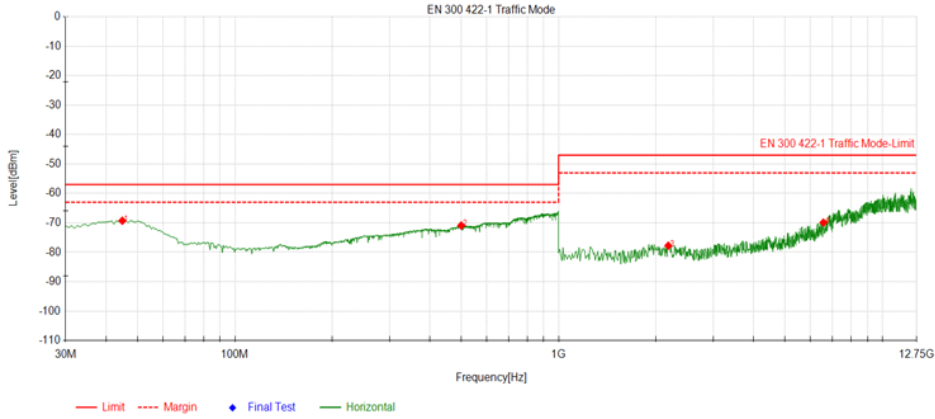

Suspected Data List								
NO.	Freq. [MHz]	Reading [dBm]	Level [dBm]	Limit [dBm]	Margin [dB]	Factor [dB]	Path [dB]	Polarity
1	44.8733	-66.28	-69.28	-57.00	12.28	-3.00	-30.56	Horizontal
2	500.1267	-65.71	-70.91	-57.00	13.91	-5.20	-30.65	Horizontal
3	2182.833	-66.52	-77.78	-47.00	30.78	-11.26	-49.17	Horizontal
4	6577.333	-65.88	-69.93	-47.00	22.93	-4.05	-45.14	Horizontal

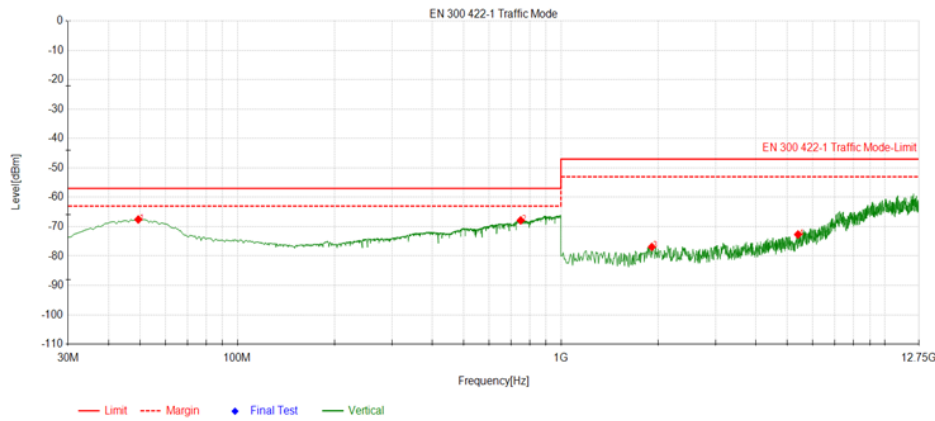

Suspected Data List								
NO.	Freq. [MHz]	Reading [dBm]	Level [dBm]	Limit [dBm]	Margin [dB]	Factor [dB]	Path [dB]	Polarity
1	49.4	-66.11	-67.56	-57.00	10.56	-1.45	-30.44	Vertical
2	750.3867	-65.96	-67.87	-57.00	10.87	-1.91	-30.65	Vertical
3	1908.666	-66.12	-76.91	-47.00	29.91	-10.79	-48.30	Vertical
4	5402.333	-65.46	-72.67	-47.00	25.67	-7.21	-47.07	Vertical



Rx in operation mode lowest carrier = 690.00 MHz

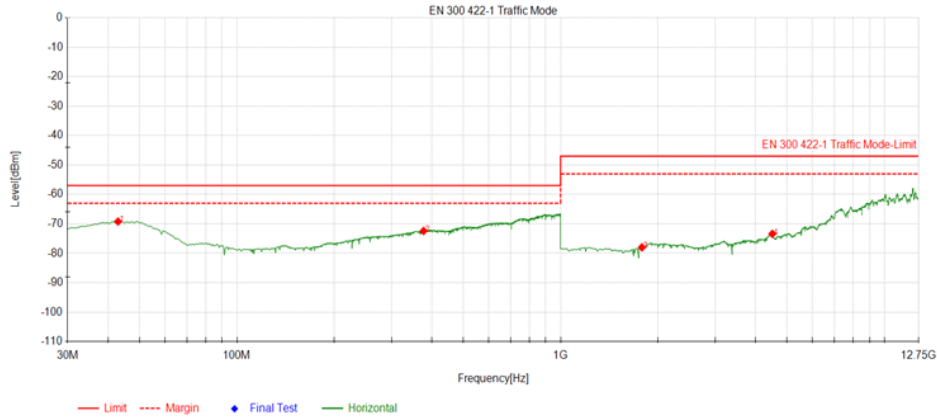

Suspected Data List								
NO.	Freq. [MHz]	Reading [dBm]	Level [dBm]	Limit [dBm]	Margin [dB]	Factor [dB]	Path [dB]	Polarity
1	42.9333	-66.21	-69.21	-57.00	12.21	-3.00	-30.61	Horizontal
2	377.26	-65.72	-72.42	-57.00	15.42	-6.70	-30.58	Horizontal
3	1783.333	-65.82	-77.99	-47.00	30.99	-12.17	-48.76	Horizontal
4	4509.333	-65.73	-73.40	-47.00	26.40	-7.67	-47.59	Horizontal

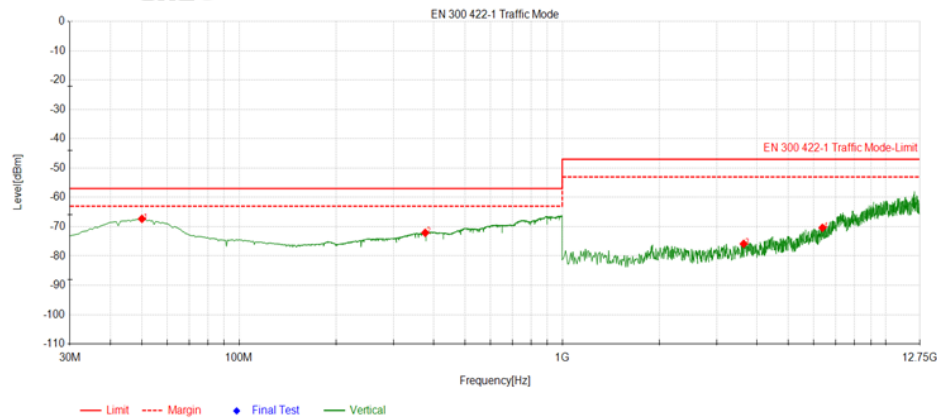

Suspected Data List								
NO.	Freq. [MHz]	Reading [dBm]	Level [dBm]	Limit [dBm]	Margin [dB]	Factor [dB]	Path [dB]	Polarity
1	50.0467	-65.94	-67.33	-57.00	10.33	-1.39	-30.42	Vertical
2	376.6133	-65.43	-72.10	-57.00	15.10	-6.67	-30.58	Vertical
3	3639.833	-65.60	-75.84	-47.00	28.84	-10.24	-48.48	Vertical
4	6381.5	-66.18	-70.39	-47.00	23.39	-4.21	-45.55	Vertical

**Remark:**

- The test frequency range from 25MHz to 10GHz, RBW/VBW: 100 KHz/300KHz below 1GHz, RBW/VBW: 1000 KHz/3000KHz above 1GHz.
- “--“Other emission levels were very low against the limit and not reported.

### 3.7. Receiver sensitivity

**LIMIT**

Receiver sensitivity shall be classified according to the limits as below:

Receiver category	Limits
A	$Rx_{sensitivity} \leq -90 \text{ dBm}$
B	$-90 \text{ dBm} < Rx_{sensitivity} \leq -70 \text{ dBm}$
C	$-70 \text{ dBm} < Rx_{sensitivity} \leq -50 \text{ dBm}$

**TEST CONFIGURATION**

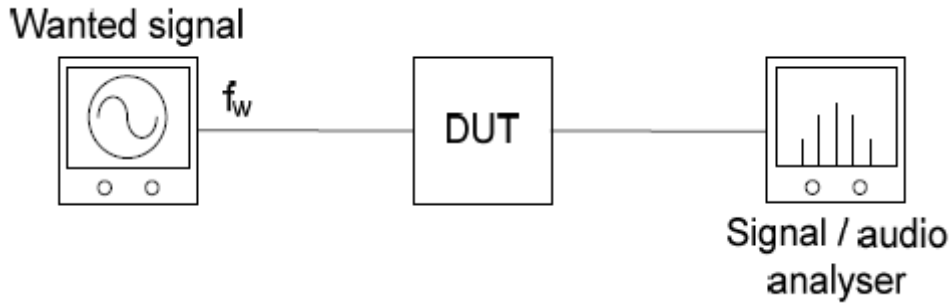

**TEST PROCEDURE**

1. Please refer to ETSI EN 300 422-1 clause 5.1 for the test conditions.
2. Please refer to ETSI EN 300 422-1 clause 5.5.1 for the measurement method.

**TEST RESULTS**

Test frequency (MHz)	Measurement Receiver sensitivity (dBm)	Limit	Test result
660.30	-108	$Rx_{sensitivity} \leq -90 \text{ dBm}$	PASS
675.00	-103		PASS
690.00	-100		PASS

### 3.8. Receiver adjacent channel selectivity

**LIMIT**

Receiver adjacent channel selectivity shall be classified according to the limits as below:

Receiver category	Limits
A	30 dB
B	See ETSI EN 300 422-2 [i.20]
C	See ETSI EN 300 422-3 [i.21]

**TEST CONFIGURATION**

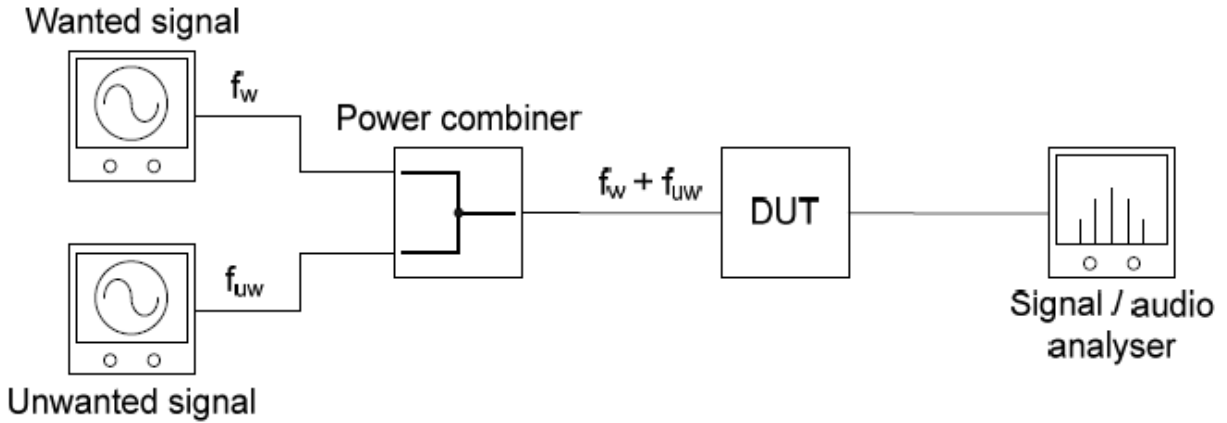

**TEST PROCEDURE**

1. Please refer to ETSI EN 300 422-1 clause 5.1 for the test conditions.
2. Please refer to ETSI EN 300 422-1 clause 5.5.2 for the measurement method.

**TEST RESULTS**

Test frequency (MHz)	Wanted signal (dBm)	Measurement Unwanted signal (dBm)		The Ratio of Unwanted signal to Wanted signal (dB)		Limit	Test result
		Lower adjacent channel	Upper adjacent channel	Lower adjacent channel	Upper adjacent channel		
660.30	-97	-55	-55	42	42	30 dB	PASS
675.00	-97	-58	-53	39	44	30 dB	PASS
690.00	-97	-53	-54	44	43	30 dB	PASS

Note: Test wanted signal is set to 3 dB above  $RX_{sensitivity}$ .

### 3.9. Receiver blocking

#### LIMIT

Receiver blocking shall be classified according to the limits as below:

Receiver category	Limits
A	40 dB
B	See ETSI EN 300 422-2 [i.20]
C	See ETSI EN 300 422-3 [i.21]

#### TEST CONFIGURATION

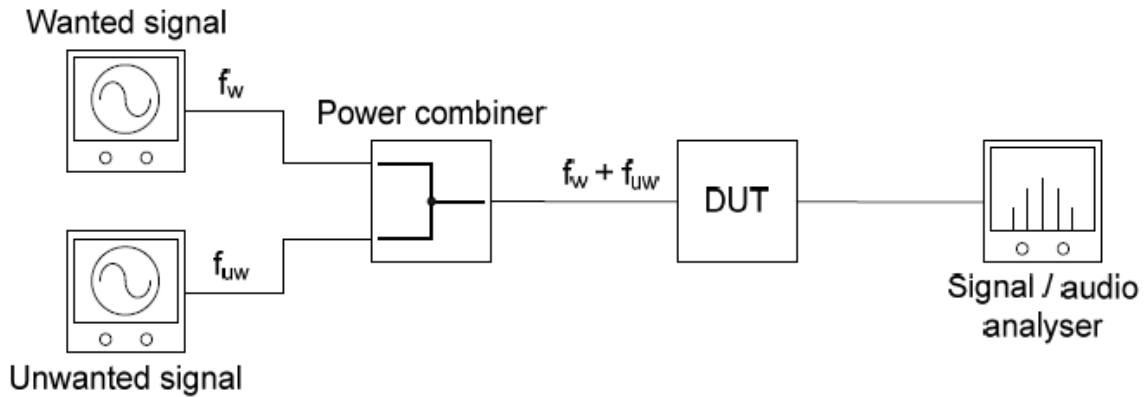

#### TEST PROCEDURE

1. Please refer to ETSI EN 300 422-1 clause 5.1 for the test conditions.
2. Please refer to ETSI EN 300 422-1 clause 5.5.3 for the measurement method.

#### TEST RESULTS

Test Frequency (MHz)	Frequency Offset	Wanted signal (dBm)	Measurement Unwanted signal (dBm)	The Ratio of Unwanted signal to Wanted signal (dB)	Limit (dB)	Result
660.30	25 × B	-97	-48	49	40	PASS
	10 × B	-97	-48	49	40	PASS
	5 × B	-97	-43	54	40	PASS
	3 × B	-97	-44	53	40	PASS
	3 × B	-97	-41	56	40	PASS
	5 × B	-97	-41	56	40	PASS
	10 × B	-97	-46	51	40	PASS
	25 × B	-97	-42	55	40	PASS

Test Frequency (MHz)	Frequency Offset	Wanted signal (dBm)	Measurement Unwanted signal (dBm)	The Ratio of Unwanted signal to Wanted signal (dB)	Limit (dB)	Result
675.00	25 × B	-97	-46	51	40	PASS
	10 × B	-97	-43	54	40	PASS
	5 × B	-97	-48	49	40	PASS
	3 × B	-97	-44	53	40	PASS
	3 × B	-97	-41	56	40	PASS
	5 × B	-97	-48	49	40	PASS
	10 × B	-97	-40	57	40	PASS
	25 × B	-97	-44	53	40	PASS
Test Frequency (MHz)	Frequency Offset	Wanted signal (dBm)	Measurement Unwanted signal (dBm)	The Ratio of Unwanted signal to Wanted signal (dB)	Limit (dB)	Result
690.00	25 × B	-97	-42	55	40	PASS
	10 × B	-97	-50	47	40	PASS
	5 × B	-97	-48	49	40	PASS
	3 × B	-97	-47	50	40	PASS
	3 × B	-97	-47	50	40	PASS
	5 × B	-97	-42	55	40	PASS
	10 × B	-97	-47	50	40	PASS
	25 × B	-97	-47	50	40	PASS

Note:

1. Test wanted signal is set to 3 dB above  $R_{X_{sensitivity}}$ .
2. Where B is the channel Bandwidth Declared by the manufacturer.



### 4. Test Setup Photos of the EUT

TX:

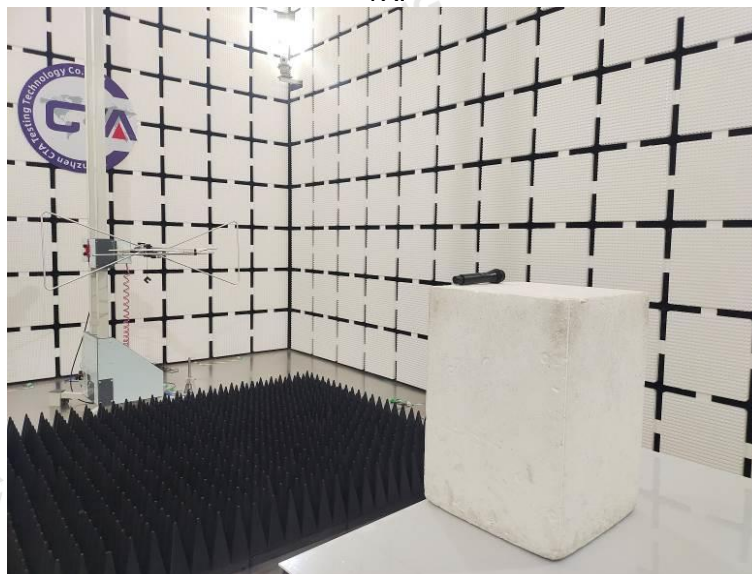

RX:

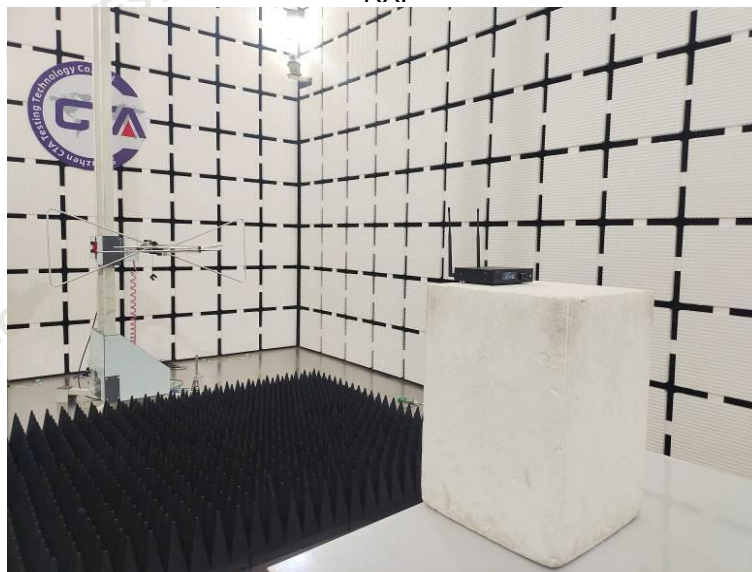





## 5. External and Internal Photos of the EUT

Reference to the test report No. CTA24082301102

\*\*\*\*\* End of Report \*\*\*\*\*